

Definition

Example -
Pyramid

Example -
Factorial

Example -
Fibonacci

How
Recursion
Works

Recursion on
Linked Lists

Example - List
Sum

Example - List
Append

How to Use
Recursion

Exercises

Recursive
Helper
Functions

Recursion vs.
Iteration

COMP2521 24T3

Recursion

Sushmita Ruj

`cs2521@cse.unsw.edu.au`

Definition

Example -
Pyramid

Example -
Factorial

Example -
Fibonacci

How
Recursion
Works

Recursion on
Linked Lists

Example - List
Sum

Example - List
Append

How to Use
Recursion

Exercises

Recursive
Helper
Functions

Recursion vs.
Iteration



Definition

Example -
PyramidExample -
FactorialExample -
FibonacciHow
Recursion
WorksRecursion on
Linked ListsExample - List
SumExample - List
AppendHow to Use
Recursion

Exercises

Recursive
Helper
FunctionsRecursion vs.
Iteration

Recursion...

is a problem solving strategy where problems are solved via
solving **smaller or simpler instances of the same problem**

A recursive function calls itself

Definition

**Example -
Pyramid**

Example -
Factorial

Example -
Fibonacci

How
Recursion
Works

Recursion on
Linked Lists

Example - List
Sum

Example - List
Append

How to Use
Recursion

Exercises

Recursive
Helper
Functions

Recursion vs.
Iteration

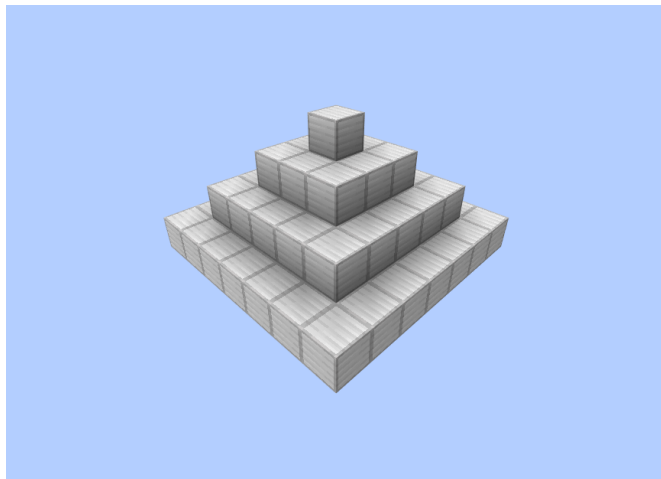

Definition

Example -
Pyramid

Example -
Factorial

Example -
Fibonacci

How
Recursion
Works

Recursion on
Linked Lists

Example - List
Sum

Example - List
Append

How to Use
Recursion

Exercises

Recursive
Helper
Functions

Recursion vs.
Iteration

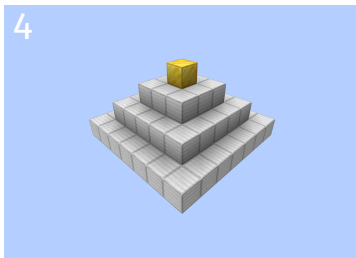
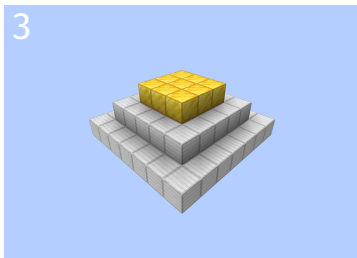
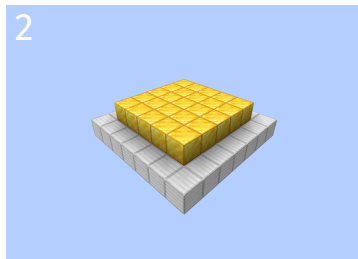

Definition

Example -
PyramidExample -
FactorialExample -
FibonacciHow
Recursion
WorksRecursion on
Linked ListsExample - List
SumExample - List
AppendHow to Use
Recursion

Exercises

Recursive
Helper
FunctionsRecursion vs.
Iteration

To build a pyramid of width n :

- For each width w from n down to 1 (decrementing by 2 each time):
 - Build a $w \times w$ layer of blocks on top

Definition

Example -
Pyramid

Example -
Factorial

Example -
Fibonacci

How
Recursion
Works

Recursion on
Linked Lists

Example - List
Sum

Example - List
Append

How to Use
Recursion

Exercises

Recursive
Helper
Functions

Recursion vs.
Iteration



Build a 7 x 7 layer of blocks

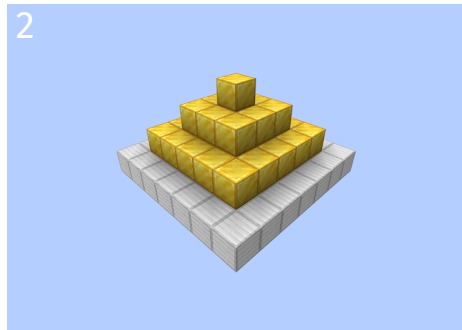

Build a pyramid of width 5 on top!

Definition

Example -
PyramidExample -
FactorialExample -
FibonacciHow
Recursion
WorksRecursion on
Linked ListsExample - List
SumExample - List
AppendHow to Use
Recursion

Exercises

Recursive
Helper
FunctionsRecursion vs.
Iteration

To build a pyramid of width n :

- 1 Build an $n \times n$ layer
- 2 Then *build a pyramid of width $n - 2$ on top*

Definition

Example -
PyramidExample -
FactorialExample -
FibonacciHow
Recursion
WorksRecursion on
Linked ListsExample - List
SumExample - List
AppendHow to Use
Recursion

Exercises

Recursive
Helper
FunctionsRecursion vs.
Iteration

To build a pyramid of width n :

- 1 Build an $n \times n$ layer
- 2 Then *build a pyramid of width $n - 2$ on top*

What's wrong with this method?

Definition

Example -
PyramidExample -
FactorialExample -
FibonacciHow
Recursion
WorksRecursion on
Linked ListsExample - List
SumExample - List
AppendHow to Use
Recursion

Exercises

Recursive
Helper
FunctionsRecursion vs.
Iteration

To build a pyramid of width n :

- 1 If $n \leq 0$, do nothing
- 2 Otherwise:
 - 1 Build an $n \times n$ layer
 - 2 Then *build a pyramid of width $n - 2$* on top

Definition

Example -
Pyramid**Example -
Factorial**Example -
FibonacciHow
Recursion
WorksRecursion on
Linked ListsExample - List
SumExample - List
AppendHow to Use
Recursion

Exercises

Recursive
Helper
FunctionsRecursion vs.
Iteration

The factorial of n (where $n \geq 0$)
denoted by $n!$
is the product of all positive integers
less than or equal to n .

$$n! = n \times (n - 1) \times (n - 2) \times \cdots \times 2 \times 1$$

Definition

Example -
PyramidExample -
FactorialExample -
FibonacciHow
Recursion
WorksRecursion on
Linked ListsExample - List
SumExample - List
AppendHow to Use
Recursion

Exercises

Recursive
Helper
FunctionsRecursion vs.
Iteration

Iterative method:

```
int factorial(int n) {  
    int res = 1;  
    for (int i = 1; i <= n; i++) {  
        res *= i;  
    }  
    return res;  
}
```

Definition

Example -
Pyramid**Example -
Factorial**Example -
FibonacciHow
Recursion
WorksRecursion on
Linked ListsExample - List
SumExample - List
AppendHow to Use
Recursion

Exercises

Recursive
Helper
FunctionsRecursion vs.
Iteration**Observation:**

$$\begin{aligned}n! &= n \times (n - 1) \times (n - 2) \times \cdots \times 2 \times 1 \\ &= n \times (n - 1)!\end{aligned}$$

For example:

$$\begin{aligned}4! &= 4 \times 3 \times 2 \times 1 \\ &= 4 \times 3!\end{aligned}$$

Definition

Example -
Pyramid**Example -
Factorial**Example -
FibonacciHow
Recursion
WorksRecursion on
Linked ListsExample - List
SumExample - List
AppendHow to Use
Recursion

Exercises

Recursive
Helper
FunctionsRecursion vs.
Iteration

Recursive method:

```
int factorial(int n) {  
    return n * factorial(n - 1);  
}
```

Definition

Example -
Pyramid**Example -
Factorial**Example -
FibonacciHow
Recursion
WorksRecursion on
Linked ListsExample - List
SumExample - List
AppendHow to Use
Recursion

Exercises

Recursive
Helper
FunctionsRecursion vs.
Iteration

Recursive method:

```
int factorial(int n) {  
    return n * factorial(n - 1);  
}
```

What's wrong with this function?

Definition

Example -
PyramidExample -
FactorialExample -
FibonacciHow
Recursion
WorksRecursion on
Linked ListsExample - List
SumExample - List
AppendHow to Use
Recursion

Exercises

Recursive
Helper
FunctionsRecursion vs.
Iteration

Recursive method:

```
int factorial(int n) {  
    if (n == 0) {  
        return 1;  
    } else {  
        return n * factorial(n - 1);  
    }  
}
```

Definition

Example -
PyramidExample -
FactorialExample -
FibonacciHow
Recursion
WorksRecursion on
Linked ListsExample - List
SumExample - List
AppendHow to Use
Recursion

Exercises

Recursive
Helper
FunctionsRecursion vs.
Iteration

Example:

```
factorial(3) = 3 * factorial(2)
              = 3 * (2 * factorial(1))
              = 3 * (2 * (1 * factorial(0)))
              = 3 * (2 * (1 * 1))
              = 3 * (2 * 1)
              = 3 * 2
              = 6
```

Definition

Example -
PyramidExample -
FactorialExample -
FibonacciHow
Recursion
WorksRecursion on
Linked ListsExample - List
SumExample - List
AppendHow to Use
Recursion

Exercises

Recursive
Helper
FunctionsRecursion vs.
Iteration

The Fibonacci sequence is a sequence where each number is the sum of the two previous numbers, and the first two numbers in the sequence are 0 and 1.

$$F_0 = 0$$

$$F_1 = 1$$

$$F_n = F_{n-1} + F_{n-2}$$

Definition

Example -
PyramidExample -
FactorialExample -
FibonacciHow
Recursion
WorksRecursion on
Linked ListsExample - List
SumExample - List
AppendHow to Use
Recursion

Exercises

Recursive
Helper
FunctionsRecursion vs.
Iteration

Recursive method:

```
int fib(int n) {  
    if (n == 0) {  
        return 0;  
    } else if (n == 1) {  
        return 1;  
    } else {  
        return fib(n - 1) + fib(n - 2);  
    }  
}
```

Definition

Example -
PyramidExample -
FactorialExample -
FibonacciHow
Recursion
WorksRecursion on
Linked ListsExample - List
SumExample - List
AppendHow to Use
Recursion

Exercises

Recursive
Helper
FunctionsRecursion vs.
Iteration

- A recursive function calls itself
- This is possible because there is a difference between a *function* and a *function call*
- Each function call creates a new mini-environment, called a *stack frame*, that holds all the local variables used by the function call

Definition

Example -
PyramidExample -
FactorialExample -
FibonacciHow
Recursion
WorksRecursion on
Linked ListsExample - List
SumExample - List
AppendHow to Use
Recursion

Exercises

Recursive
Helper
FunctionsRecursion vs.
Iteration

Consider this program (no recursion):

```
int main(void) {  
    a(5);  
}  
  
void a(int val) {  
    b(val);  
}  
  
void b(int val) {  
    printf("%d\n", val);  
}
```

This is how the state of the stack changes:

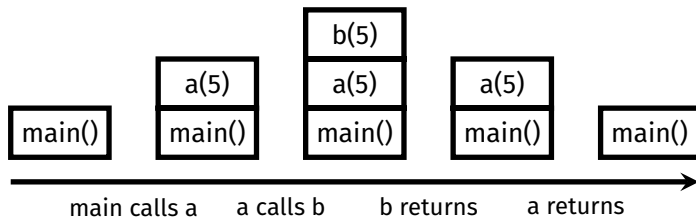

Definition

Example -
PyramidExample -
FactorialExample -
FibonacciHow
Recursion
WorksRecursion on
Linked ListsExample - List
SumExample - List
AppendHow to Use
Recursion

Exercises

Recursive
Helper
FunctionsRecursion vs.
IterationNow consider `factorial(2)`:

```
int factorial(int n) {  
    if (n == 0) {  
        return 1;  
    } else {  
        return n * factorial(n - 1);  
    }  
}
```

This is how the state of the stack changes:

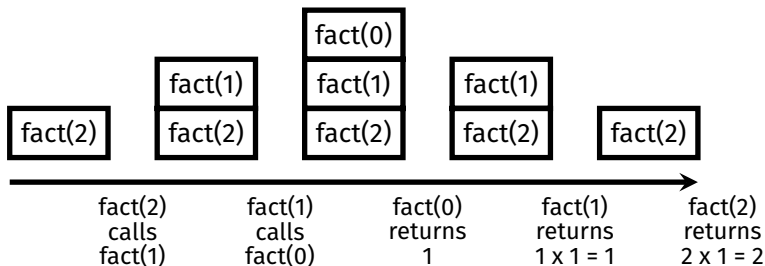

When the stack is growing, that is called “winding”

When the stack is shrinking, that is called “unwinding”

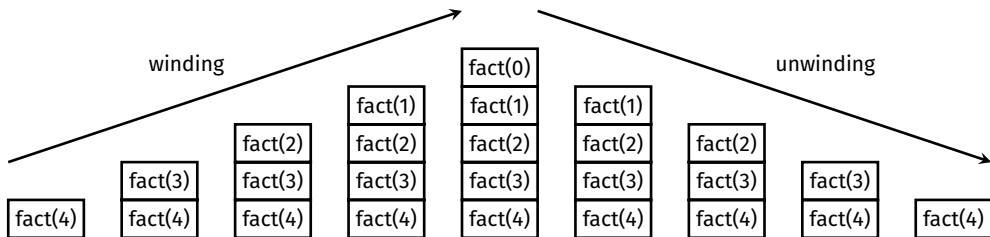

Definition

Example -
PyramidExample -
FactorialExample -
FibonacciHow
Recursion
WorksRecursion on
Linked ListsExample - List
SumExample - List
AppendHow to Use
Recursion

Exercises

Recursive
Helper
FunctionsRecursion vs.
Iteration

Definition

Example -
PyramidExample -
FactorialExample -
FibonacciHow
Recursion
WorksRecursion on
Linked ListsExample - List
SumExample - List
AppendHow to Use
Recursion

Exercises

Recursive
Helper
FunctionsRecursion vs.
Iteration

Pre-order operations

Operations **before** the recursive call occur during winding.

Post-order operations

Operations **after** the recursive call occur during unwinding.

Definition

Example -
PyramidExample -
FactorialExample -
FibonacciHow
Recursion
WorksRecursion on
Linked ListsExample - List
SumExample - List
AppendHow to Use
Recursion

Exercises

Recursive
Helper
FunctionsRecursion vs.
Iteration

Recall that recursion is
a problem solving strategy where problems are solved via
solving **smaller or simpler instances of the same problem**

How do we apply recursion to linked lists?

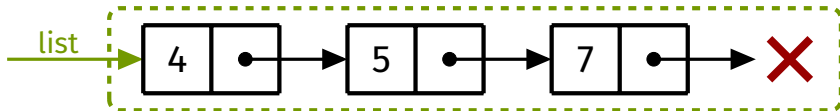

Definition

Example -
PyramidExample -
FactorialExample -
FibonacciHow
Recursion
WorksRecursion on
Linked ListsExample - List
SumExample - List
AppendHow to Use
Recursion

Exercises

Recursive
Helper
FunctionsRecursion vs.
Iteration

Recall that recursion is
a problem solving strategy where problems are solved via
solving **smaller or simpler instances of the same problem**

How do we apply recursion to linked lists?

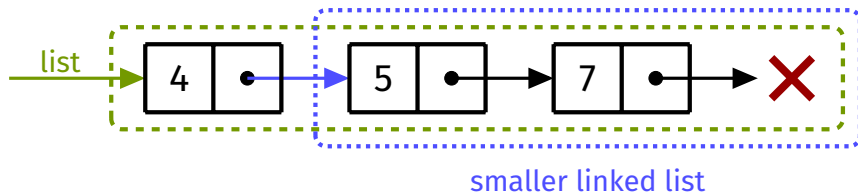

Definition

Example -
PyramidExample -
FactorialExample -
FibonacciHow
Recursion
WorksRecursion on
Linked ListsExample - List
SumExample - List
AppendHow to Use
Recursion

Exercises

Recursive
Helper
FunctionsRecursion vs.
Iteration

Example: summing values of a list

- Base case: empty list
 - Sum of an empty list is zero
- Non-empty lists
 - I can't solve the whole problem directly
 - But I do know the first value in the list
 - And if I can sum the rest of the list (smaller than whole list)
 - Then I can add the first value to the sum of the rest of the list, giving the sum of the whole list

Definition

Example -
PyramidExample -
FactorialExample -
FibonacciHow
Recursion
WorksRecursion on
Linked Lists**Example - List
Sum**Example - List
AppendHow to Use
Recursion

Exercises

Recursive
Helper
FunctionsRecursion vs.
Iteration

Example:

```
listSum([3, 1, 4]) = 3 + listSum([1, 4])  
                  = 3 + (1 + listSum([4]))  
                  = 3 + (1 + (4 + listSum([])))  
                  = 3 + (1 + (4 + 0))  
                  = 3 + (1 + 4)  
                  = 3 + 5  
                  = 8
```

Definition

Example -
PyramidExample -
FactorialExample -
FibonacciHow
Recursion
WorksRecursion on
Linked ListsExample - List
SumExample - List
AppendHow to Use
Recursion

Exercises

Recursive
Helper
FunctionsRecursion vs.
Iteration

Recursive method:

```
struct node {
    int value;
    struct node *next;
};

int listSum(struct node *list) {
    if (list == NULL) {
        return 0;
    } else {
        return list->value + listSum(list->next);
    }
}
```

Definition

Example -
PyramidExample -
FactorialExample -
FibonacciHow
Recursion
WorksRecursion on
Linked ListsExample - List
SumExample - List
AppendHow to Use
Recursion

Exercises

Recursive
Helper
FunctionsRecursion vs.
Iteration

Example: append a value to a list

```
struct node *listAppend(struct node *list, int value) {  
    ...  
}
```

`listAppend` should insert the given value at the end of the given list and return a pointer to the start of the updated list.

Definition

Example -
PyramidExample -
FactorialExample -
FibonacciHow
Recursion
WorksRecursion on
Linked ListsExample - List
Sum**Example - List
Append**How to Use
Recursion

Exercises

Recursive
Helper
FunctionsRecursion vs.
Iteration

What's wrong with this solution?

```
1 struct node *listAppend(struct node *list, int value) {
2     if (list == NULL) {
3         return newNode(value);
4     } else {
5         listAppend(list->next, value);
6         return list;
7     }
8 }
```

Definition

Example -
PyramidExample -
FactorialExample -
FibonacciHow
Recursion
WorksRecursion on
Linked ListsExample - List
SumExample - List
AppendHow to Use
Recursion

Exercises

Recursive
Helper
FunctionsRecursion vs.
Iteration

```
1 struct node *listAppend(struct node *list, int value) {
2     if (list == NULL) {
3         return newNode(value);
4     } else {
5         listAppend(list->next, value);
6         return list;
7     }
8 }
```

Consider this list...

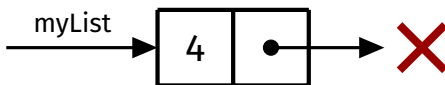

...and this function call:

```
listAppend(myList, 5);
```

Definition

Example -
PyramidExample -
FactorialExample -
FibonacciHow
Recursion
WorksRecursion on
Linked ListsExample - List
SumExample - List
AppendHow to Use
Recursion

Exercises

Recursive
Helper
FunctionsRecursion vs.
Iteration

```
1 struct node *listAppend(struct node *list, int value) {
2     if (list == NULL) {
3         return newNode(value);
4     } else {
5         listAppend(list->next, value);
6         return list;
7     }
8 }
```

The recursive call on line 5 creates a new node and returns it...



...but this new node is not attached to the list!
The node containing 4 still points to NULL.

Definition

Example -
PyramidExample -
FactorialExample -
FibonacciHow
Recursion
WorksRecursion on
Linked ListsExample - List
SumExample - List
AppendHow to Use
Recursion

Exercises

Recursive
Helper
FunctionsRecursion vs.
Iteration

Correct solution:

```
1 struct node *listAppend(struct node *list, int value) {
2     if (list == NULL) {
3         return newNode(value);
4     } else {
5         list->next = listAppend(list->next, value);
6         return list;
7     }
8 }
```

Definition

Example -
PyramidExample -
FactorialExample -
FibonacciHow
Recursion
WorksRecursion on
Linked ListsExample - List
SumExample - List
AppendHow to Use
Recursion

Exercises

Recursive
Helper
FunctionsRecursion vs.
Iteration

Why does this work?

```
list->next = listAppend(list->next, value);
```

Consider the following list:



Two cases to consider:

- (1) The rest of the list is empty
- (2) The rest of the list is not empty

```
list->next = listAppend(list->next, value);
```

Case 1: The rest of the list is empty



Definition

Example -
PyramidExample -
FactorialExample -
FibonacciHow
Recursion
WorksRecursion on
Linked ListsExample - List
Sum**Example - List
Append**How to Use
Recursion

Exercises

Recursive
Helper
FunctionsRecursion vs.
Iteration

```
list->next = listAppend(list->next, value);
```

Case 1: The rest of the list is empty

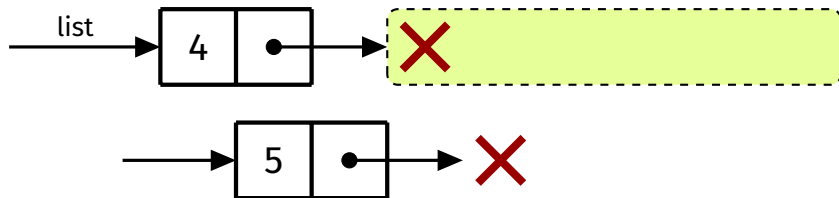

In this case, `listAppend(list->next, value)` will return a new node

```
list->next = listAppend(list->next, value);
```

Case 1: The rest of the list is empty

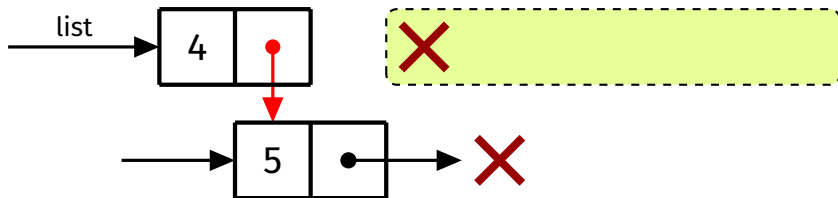

In this case, `listAppend(list->next, value)` will return a new node
`list->next = ...` causes `list->next` to point to this new node

```
list->next = listAppend(list->next, value);
```

Case 2: The rest of the list is **not** empty



Definition

Example -
PyramidExample -
FactorialExample -
FibonacciHow
Recursion
WorksRecursion on
Linked ListsExample - List
Sum**Example - List
Append**How to Use
Recursion

Exercises

Recursive
Helper
FunctionsRecursion vs.
Iteration

```
list->next = listAppend(list->next, value);
```

Case 2: The rest of the list is **not** empty

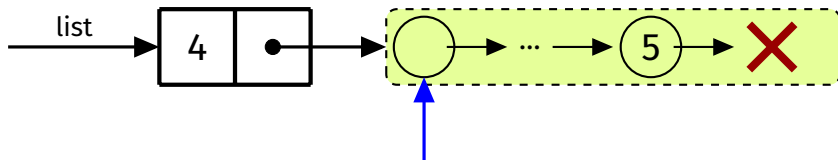

In this case, `listAppend(...)` will append the value to the rest of the list and return a **pointer to the (start of the) rest of the list**

```
list->next = listAppend(list->next, value);
```

Case 2: The rest of the list is **not** empty

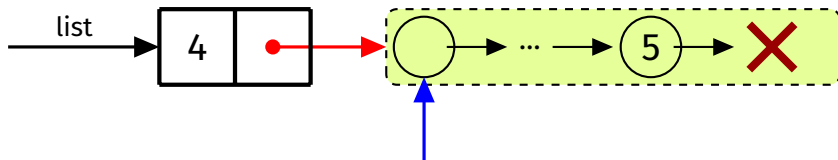

In this case, `listAppend(...)` will append the value to the rest of the list and return a **pointer to the (start of the) rest of the list**

`list->next = ...` causes `list->next` to point to the start of the rest of the list (which it was already pointing to)

Definition

Example -
PyramidExample -
FactorialExample -
FibonacciHow
Recursion
WorksRecursion on
Linked ListsExample - List
SumExample - List
AppendHow to Use
Recursion

Exercises

Recursive
Helper
FunctionsRecursion vs.
Iteration

- 1 Consider whether using recursion is appropriate
 - Can the solution be expressed in terms of a smaller instance of the same problem?
- 2 Identify the base case(s)
- 3 Identify the subproblem(s)
 - **Assume** that the function works for the subproblem(s)
 - Like in mathematical induction!
- 4 Think about how to relate the original problem to the subproblem(s)

Definition

Example -
PyramidExample -
FactorialExample -
FibonacciHow
Recursion
WorksRecursion on
Linked ListsExample - List
SumExample - List
AppendHow to Use
Recursion

Exercises

Recursive
Helper
FunctionsRecursion vs.
Iteration

Exercise 1:

- Given a linked list, print the items in the list in reverse.

Exercise 2:

- Given a linked list and an index, return the value at that index. Index 0 corresponds to the first value, index 1 the second value, and so on.

Exercise 3:

- Given a linked list and a value, delete the first instance of the value from the list (if it exists), and return the updated list.

Definition

Example -
Pyramid

Example -
Factorial

Example -
Fibonacci

How
Recursion
Works

Recursion on
Linked Lists

Example - List
Sum

Example - List
Append

How to Use
Recursion

Exercises

**Recursive
Helper
Functions**

Recursion vs.
Iteration

Sometimes, recursive solutions require recursive helper functions

- Data structure uses a “wrapper” struct
- Recursive function needs to take in extra information (e.g., state)

Definition

Example -
PyramidExample -
FactorialExample -
FibonacciHow
Recursion
WorksRecursion on
Linked ListsExample - List
SumExample - List
AppendHow to Use
Recursion

Exercises

Recursive
Helper
FunctionsRecursion vs.
Iteration

Wrapper struct for a linked list:

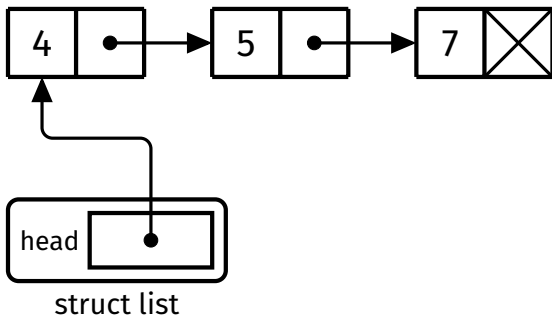

```
struct node {  
    int value;  
    struct node *next;  
};
```

```
struct list {  
    struct node *head;  
};
```

Definition

Example -
PyramidExample -
FactorialExample -
FibonacciHow
Recursion
WorksRecursion on
Linked ListsExample - List
SumExample - List
AppendHow to Use
Recursion

Exercises

Recursive
Helper
FunctionsRecursion vs.
Iteration

Example: Implement this function:

```
void listAppend(struct list *list, int value);
```

Definition

Example -
PyramidExample -
FactorialExample -
FibonacciHow
Recursion
WorksRecursion on
Linked ListsExample - List
SumExample - List
AppendHow to Use
Recursion

Exercises

Recursive
Helper
FunctionsRecursion vs.
Iteration

```
void listAppend(struct list *list, int value);
```

We can't recurse with this function because our recursive function needs to take in a struct node pointer.

Solution: Use a recursive helper function!

Definition

Example -
PyramidExample -
FactorialExample -
FibonacciHow
Recursion
WorksRecursion on
Linked ListsExample - List
SumExample - List
AppendHow to Use
Recursion

Exercises

Recursive
Helper
FunctionsRecursion vs.
Iteration

```
void listAppend(struct list *list, int value) {
    list->head = doListAppend(list->head, value);
}

struct node *doListAppend(struct node *node, int value) {
    if (node == NULL) {
        return newNode(value);
    } else {
        node->next = doListAppend(node->next, value);
        return node;
    }
}
```

Our convention for naming recursive helper functions is to prepend “do” to the name of the original function.

Definition

Example -
PyramidExample -
FactorialExample -
FibonacciHow
Recursion
WorksRecursion on
Linked ListsExample - List
SumExample - List
AppendHow to Use
Recursion

Exercises

Recursive
Helper
FunctionsRecursion vs.
Iteration

Problem:

- Print a linked list in a numbered list format, starting from 1.

```
void printNumberedList(struct node *list);
```

Example:

- Suppose the input list contains the following elements: [11, 9, 2023]
- We expect the following output:

```
1. 11
2. 9
3. 2023
```

Definition

Example -
PyramidExample -
FactorialExample -
FibonacciHow
Recursion
WorksRecursion on
Linked ListsExample - List
SumExample - List
AppendHow to Use
Recursion

Exercises

Recursive
Helper
FunctionsRecursion vs.
Iteration

We need to keep track of the current number.

Solution:

- Use a recursive helper function that takes in an extra integer

```
void printNumberedList(struct node *list) {
    doPrintNumberedList(list, 1);
}

void doPrintNumberedList(struct node *list, int num) {
    if (list == NULL) return;

    print("%d. %d\n", num, list->value);
    doPrintNumberedList(list->next, num + 1);
}
```

Definition

Example -
Pyramid

Example -
Factorial

Example -
Fibonacci

How
Recursion
Works

Recursion on
Linked Lists

Example - List
Sum

Example - List
Append

How to Use
Recursion

Exercises

Recursive
Helper
Functions

Recursion vs.
Iteration

- If there is a simple iterative solution, a recursive solution will generally be slower
 - Due to a stack frame needing to be created for each function call
- A recursive solution will generally use more memory than an iterative solution

Definition

Example -
Pyramid

Example -
Factorial

Example -
Fibonacci

How
Recursion
Works

Recursion on
Linked Lists

Example - List
Sum

Example - List
Append

How to Use
Recursion

Exercises

Recursive
Helper
Functions

Recursion vs.
Iteration



Definition

Example -
Pyramid

Example -
Factorial

Example -
Fibonacci

How
Recursion
Works

Recursion on
Linked Lists

Example - List
Sum

Example - List
Append

How to Use
Recursion

Exercises

Recursive
Helper
Functions

Recursion vs.
Iteration

<https://forms.office.com/r/P7PB8yHu38>

